

VERIFYING THE PERFORMANCE OF VECTOR NETWORK ANALYZERS

First published: July 1989; Revised and republished: July 1999 and February 2006.
Author: Mario A. Maury, Jr., MSEE; Maury Microwave Corporation

Introduction

This application note describes procedures that can be used to verify the performance and operation of a Vector Network Analyzer (VNA) using just the equipment available in a standard Maury precision calibration kit¹. The purpose is to provide the user with a level of confidence in the accuracy of the VNA system. This information is applicable to all commercially available analyzers and is independent of the type of calibration employed.

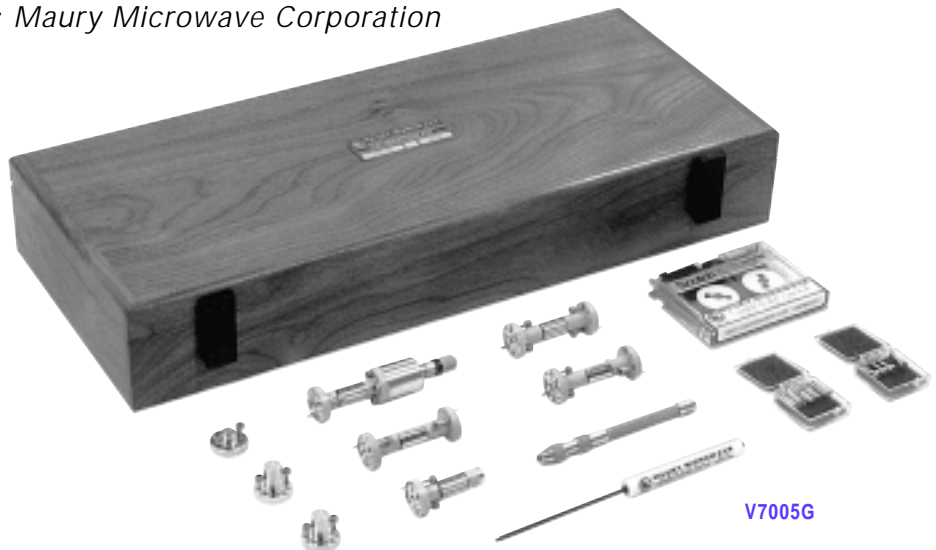

VNA Block Diagram

Figure 1 is a generic block diagram of the RF front end of a typical VNA. This assembly can be in coax, as in most commercial S-parameter test sets (Agilent 8514, 8515, etc.), or it could be an external waveguide assembly.

The simplified diagram shown is essentially a two-path, two-port test set; that is, all four S-parameters of the Device Under Test (DUT) can be measured (after suitable calibration) with a single insertion

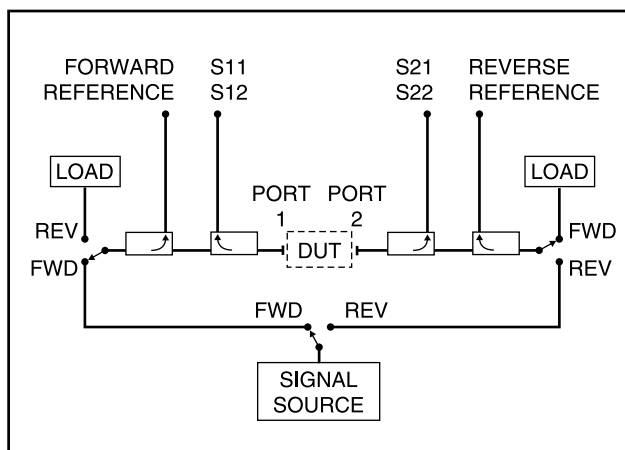

Figure 1. Simplified VNA Block Diagram

between the two test ports. This is an important consideration in some applications such as wafer probing.

In some setups, it may be physically and electrically inconvenient to reverse the direction of signal flow through switches (e.g.: mm waveguide). These are generally referred to as one-path, two-port systems. A full two-port measurement with such a system requires manually reversing the DUT between the test ports.

Error Characterization

Limitations on VNA accuracy result from two broad categories of errors: systematic errors and random (or non-repeatable) errors.

Systematic errors are repeatable, and therefore, can be measured and corrected using known calibration standards. One or more of the items included in Maury calibration kits can be used to verify analyzer performance after the calibration is complete.

Random uncertainties, by their very nature, cannot be removed from the measurement results by calibration; however, items in the calibration kit can be used to evaluate potential effects of these errors on the measurement.



The systematic errors generally considered in VNA calibration are:

Frequency response tracking errors (Figure 2) result from response differences between the reference and measurement paths. In the full two-path, two-port error model, there are four such error terms: forward reflection and reverse transmission (Port 1), and forward transmission and reverse reflection (Port 2). Response errors will affect both reflection and transmission measurements.

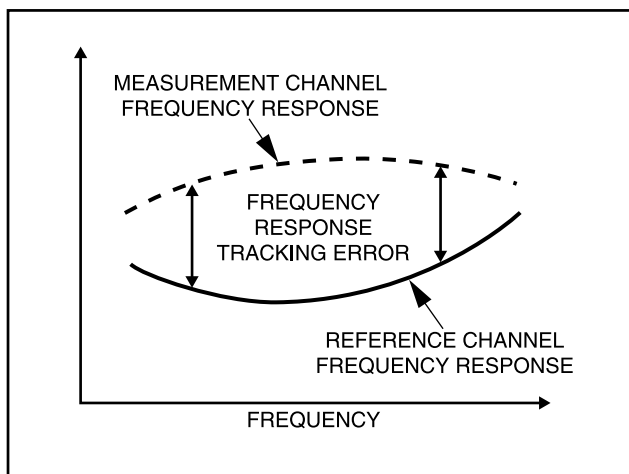

Figure 2. Response Tracking Error

Source match (Figure 4) is the mismatch between the source test port and the system characteristic impedance. Measurement errors can occur as a result of source test port reflections being re-reflected back into the system by the DUT. Source match errors are most significant in reflection measurements of devices with large reflection coefficients.

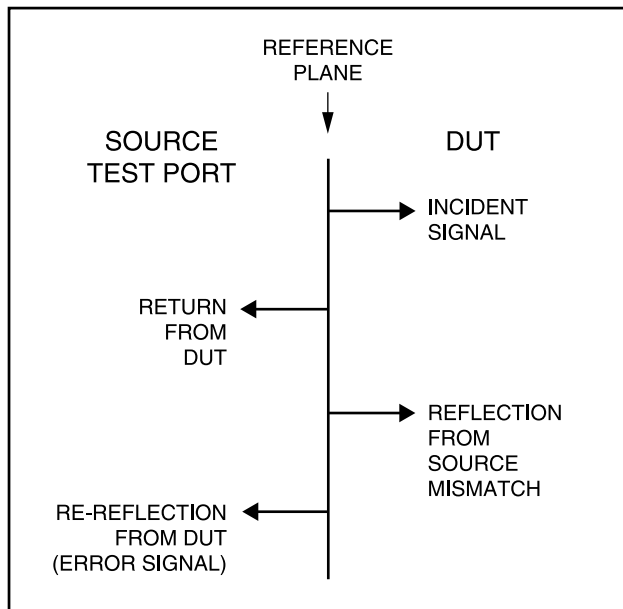

Figure 4. Source Match Error

Directivity (Figure 3) is a measure of the ability of a directional coupler to discriminate against signals traveling opposite to the coupled direction. At Port 1 for example, a small amount of power traveling toward the DUT will appear in the coupled arm causing an error in the reflected signal measurement. This signal will be below an equal signal traveling from the DUT by an amount equal to the directivity. The major effect of directivity errors is on the measurement of small reflection coefficients.

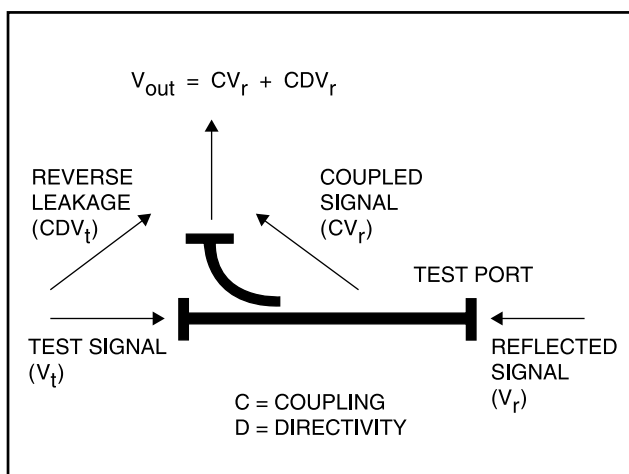

Figure 3. Directivity Error

Load match (Figure 5) refers to the mismatch between the load test port and the system characteristic impedance. Signals reflected from the load test port can be re-reflected by the output mismatch of the DUT causing a measurement error in both reflection and transmission measurements primarily when the DUT has a high output reflection coefficient and/or low transmission loss.

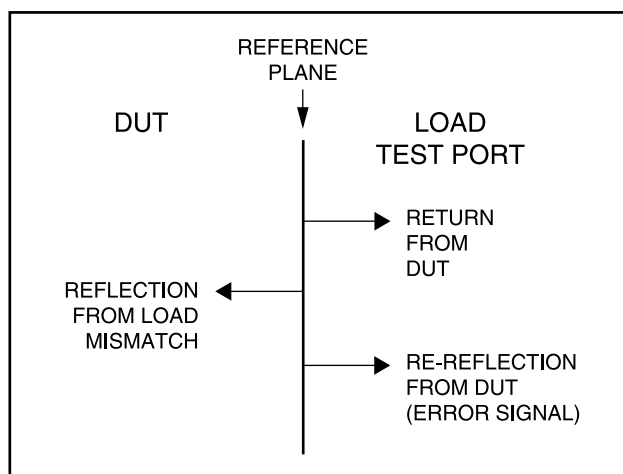

Figure 5. Load Match Error



Isolation (Figure 6) refers to the leakage between the reference and measurement channels of the test set. The major error contribution is in the measurement of large transmission losses.

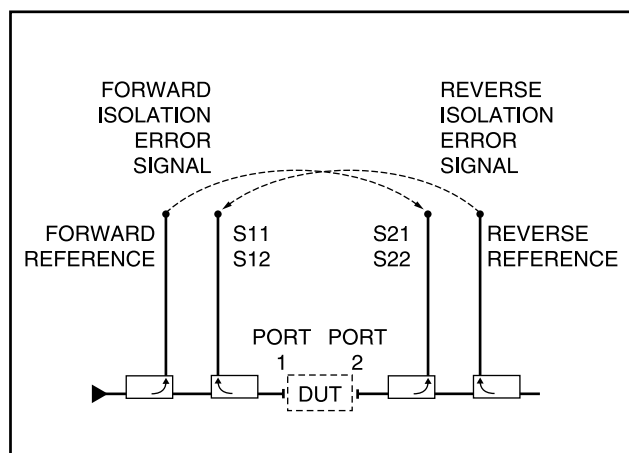

Figure 6. Isolation Error

VNA Calibration

Figure 7 is a signal flowgraph of one-path of a two-port measurement. The model contains the six error terms shown.

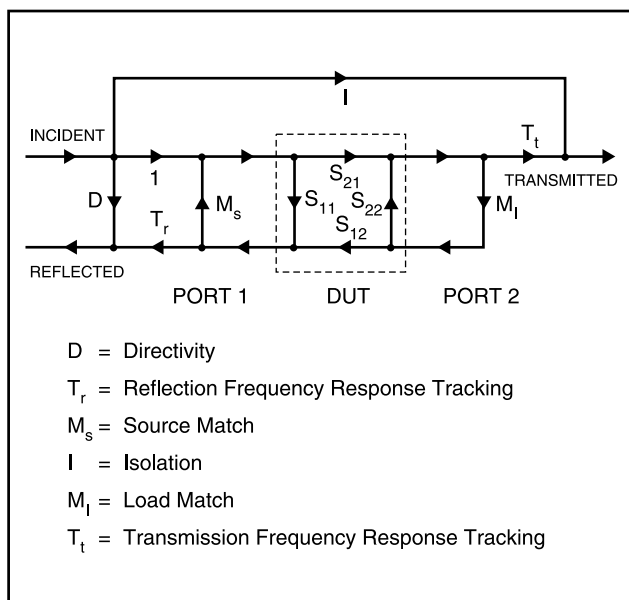

Figure 7. Forward Two-Port Error Model

A full, two-path, two-port measurement requires a second model which is the mirror image of Figure 7 with an additional set of six error terms. The two combined are referred to as the twelve-term error model.

Calibration of a vector network analyzer involves connecting sufficient known standards to or between the test ports. This permits simultaneous solution of the measurement equations resulting from the error model signal flowgraph.

There are several methods of calibration available. In many cases, the differences are in the implementation of the standards or in the extent of the calibration (e.g.: an S11 measurement of a one-port device would not generally require a full, two-port calibration).

The calibration process is actually a series of measurements starting with a one-port calibration on each test port to determine directivity, source match, and reflection response tracking. Then, two or more (depending upon whether the setup is one-path, two-port; or two-path, two-port) transmission measurements are required to determine transmission response tracking, load match, and isolation (in both directions for two-path calibrations).

Figure 8 is the error model flowgraph modified for a one-port measurement. Standard flowgraph analysis techniques result in the equation for the measured reflection coefficient shown in the figure. The equation has four unknowns; therefore, given sufficient known standards, the equation can be simultaneously solved for the error terms.

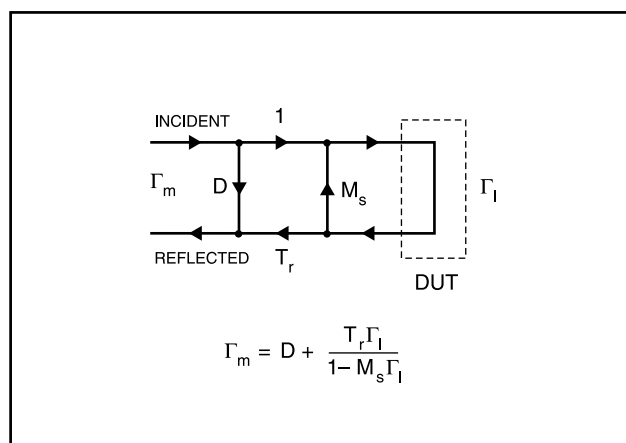

Figure 8. Error Model Modification for One-Port Measurements

The most popular technique is actually simpler in concept and requires only a good quality sliding load and two offset short circuits for waveguide, or an open and short for coaxial. Note that if a perfect load (reflection coefficient = zero) were connected to the



test port, the directivity can be measured directly. A perfect load can be simulated by moving a sliding load to several different positions. This has the effect of rotating the load error vector around the tip of the directivity vector. Using curve fitting techniques, the center of the circle (and therefore, the directivity) can be found. This procedure is generally referred to as load separation because it essentially isolates the minor imperfections of the load element from the waveguide or coaxial housing. The accuracy of the measurement then becomes a function of the load housing.

The two offset shorts (or open and short circuit) are then used to set up two additional known conditions. The two resultant equations can then be simultaneously solved for reflection response tracking and source match. Most Maury waveguide calibration kits include two short circuits with 1/8 and 3/8 wavelength offsets at the geometric mean of the frequency range. The difference in the offset need not be exactly 1/4 wavelength, and using the actual offset length will result in greater accuracy. The Maury calibration kits provide this information in media (diskette or cassette) and software format compatible with the applicable VNA.

A flush short and a 1/4 wavelength shim could be used for the same purpose. Maury Microwave does offer calibration kits incorporating the shim; however, the offset shorts are preferred because the number of flange connections are halved, thereby reducing potential random errors due to flange mating inconsistency.

The 1/8 – 3/8 wavelength offset shorts offer one other potential advantage: the currents at the test port are essentially equal with either offset short in place. With the flush short, the current is maximum. When the 1/4 wavelength shim is added, the current is at a minimum. If the flange loss at the test port is significant, the wide change in current could affect accuracy. In general, this is not a factor if both flanges are Maury MPF series precision flanges².

Transmission frequency response tracking error and load match error are determined simultaneously simply by connecting the test ports together. In the forward direction, the latter appears in the Port 1 reflection coupler, while the former appears in the Port 2 reflection coupler.

The last error term, isolation, is measured by terminating both Port 1 and Port 2 in good loads,

and measuring the signal leakage at the Port 2 forward coupler output relative to the reference.

For a full, two-path, two-port calibration, the entire calibration process described above is repeated with Port 2 as the incident port.

Verifying Calibration Accuracy

Perfect calibration of a VNA is a practical impossibility. This is primarily due to operator technique and random effects such as system sensitivity limits, noise, connection repeatability, etc. The quality of the standards will also impact the accuracy of the error correction. The quality of the calibration can be judged by measuring the residual errors after calibration.

Obviously, the same standards used to calibrate the VNA can be re-measured; however, this does not so much determine the effectiveness of the calibration as it does the repeatability of the standard and the impact of the non-repeatable factors noted above.

Many Maury VNA calibration kits contain items which, although not used in the calibration, can be used to measure the calibration's effectiveness. They may also be used – independent of the actual calibration standards – to measure some of the random or non-repeatable errors.

One factor affecting calibration effectiveness is the quality of the standards (e.g.: the mechanical accuracy of the sliding load housing). Similarly, the accuracy of residual error evaluations depends upon the quality of the components used to make the evaluations. In most cases, these components are a precision air line or straight waveguide section and/or a flush short circuit.

Mechanical accuracy is critical in both coaxial and waveguide systems. Effective directivity measurements (see [Figure 10](#)) are routinely better than 60 dB even at millimeter wave frequencies. Thus, the waveguide straight section or precision air line used for the measurements must be even better or its return loss will mask the true result. The straight section provided in Maury's WR15 calibration kit is capable of measurements in the 60–65 dB range. This translates to a worst case dimensional tolerance of about 50 millionths of an inch!



Effective Directivity

This is the term applied to the residual directivity error after the VNA has been calibrated. As indicated in **Figure 8**, effective directivity could be measured if a perfect fixed load were applied to the test port (measured reflection coefficient would be zero). Although the fixed terminations provided as part of the Maury calibration kits are excellent, even the extremely small reflections from these standards are sufficient to contaminate the effective directivity measurement with the load reflection, source match, and frequency response error terms.

Using the precision air line or waveguide and the low reflection fixed load provided in Maury calibration kits, effective directivity can be measured directly by using time domain gating. As illustrated by **Figure 9**, the effective directivity error signal is coupled off the incident signal. The load and source match reflections must transit the air line two and four times, respectively, before appearing at the reference plane.

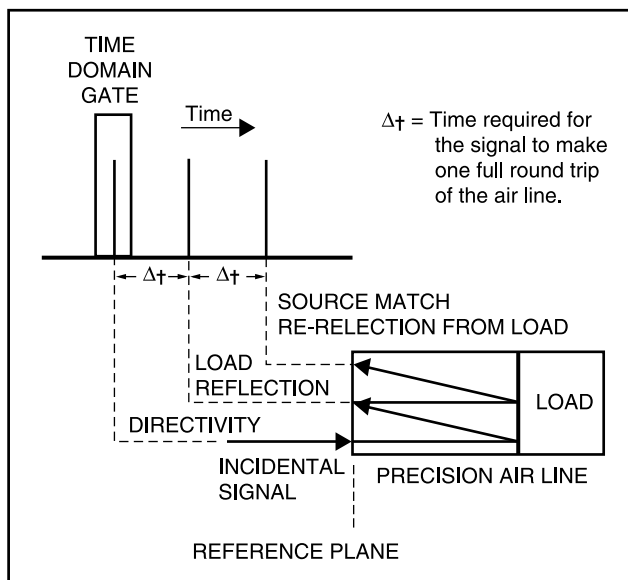

Figure 9. Time Domain Gate Isolation of Effective Directivity

By positioning the time domain gate at the test port, the effective directivity signal is separated from the remaining effects.

Figure 10 is a plot of the measured effective directivity of an Agilent 8510 VNA and a test set similar to that in **Figure 1** after a one-port calibration using the sliding load and offset shorts in the Maury V7005F calibration kit (WR15 waveguide, 50–75 GHz). The measurement was performed using the precision straight section and fixed termination provided as

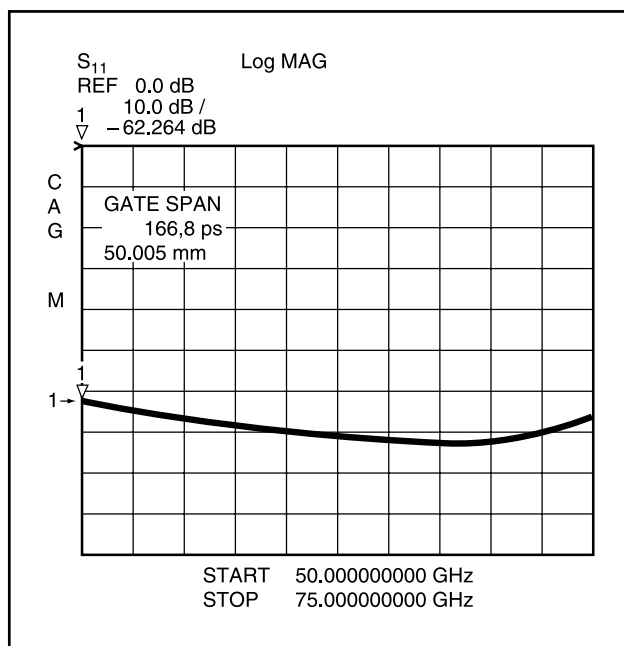

Figure 10. Effective Directivity Measurement

part of the kit. The measured effective directivity of better than 60 dB is quite typical of waveguide setups calibrated with a Maury precision calibration kit at these frequencies.

Effective Source Match

If the effective directivity were perfect (zero), and the fixed termination at the end of the air line were replaced with a flush short, then the measured reflection signal would be the sum of the vector representing the short (-1) and the effective source match vector. If the short is considered the reference, then, because of the distance displacement of the air line, the effective source match vector can be considered as rotating around the tip of the vector representing the short (see **Figure 11**) as frequency varies.

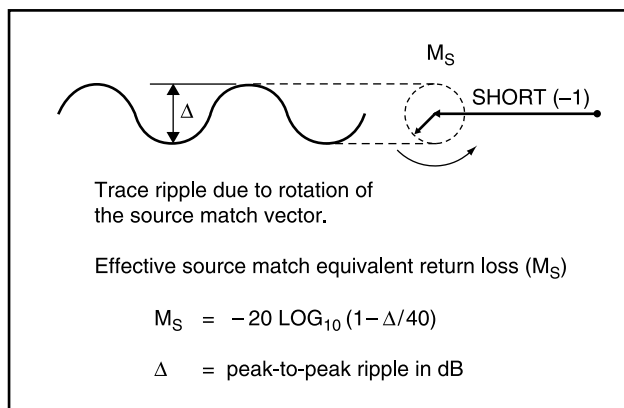

Figure 11. Effective Source Match Measurement



In a like manner, because it is not really zero, the effective directivity vector also rotates around the vector representing the short. A measurement of the reflection coefficient of the short would show a ripple due to the rotation of the two vectors with frequency; however, effective directivity has already been measured, and the measurement can be stored in the analyzer memory.

The VNA trace math feature (S11 – Memory) can then be used to display the ripple resulting from source match alone.

Effective directivity is usually about an order of magnitude smaller than the effective source match vector (in waveguide). For this reason, it is often ignored in the effective source match measure-

directivity is negligible) which is given by the equation shown in [Figure 11](#).

The worst case ripple in [Figure 13](#) indicates an effective source match equivalent return loss of about 42 dB – again, quite typical at these frequencies.

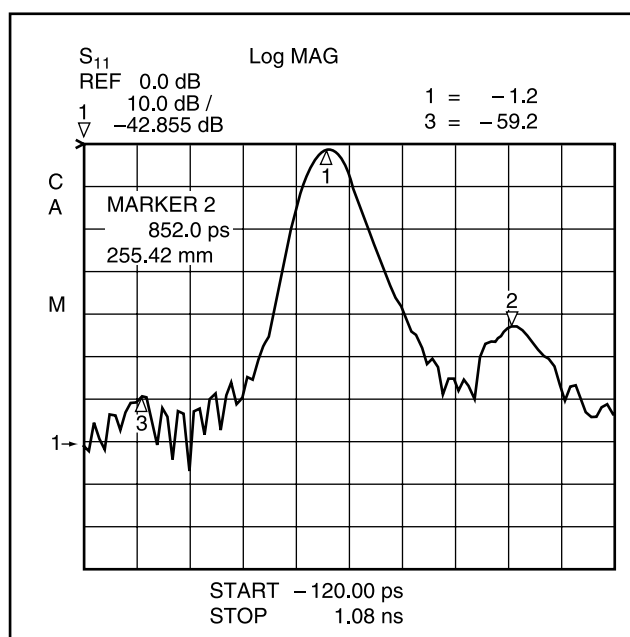

Figure 12. Time Domain Plot of a Shorted WR15 Straight Section Showing the Effective Source Match (Marker 2) and Effective Directivity (Marker 3) Responses

ment, and the trace math feature is not used. The magnitude difference is illustrated in [Figure 12](#). This is a time domain plot of an S11 measurement of the precision air line terminated by the flush short. The large response in the center is the short. The smaller signal to the right is the effective source match. Note that the effective directivity response is just barely visible to the left of the short response.

[Figure 13](#) is a frequency domain plot of the same measurement. As noted earlier, rotation of the source match vector gives rise to the ripple in the S11 response. The magnitude of the ripple is a measure of the effective source match (assuming effective

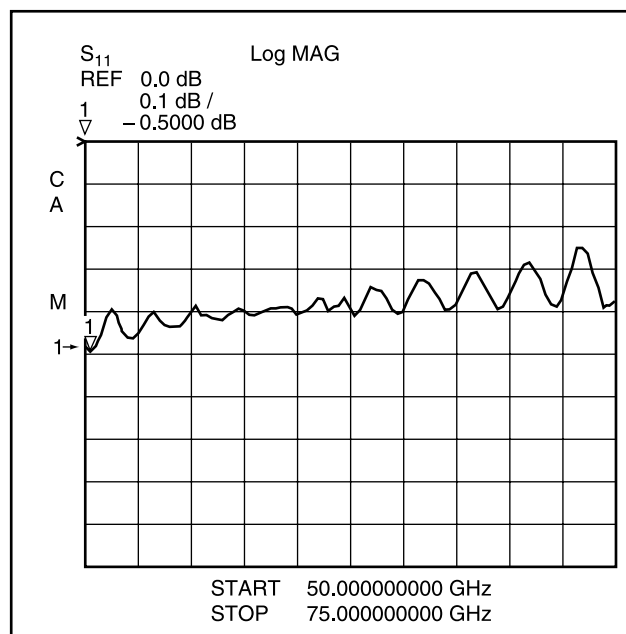

Figure 13. Effective Source Match Plot

Scaling the worst case peak-to-peak ripple and using the equation in [Figure 11](#) results in an effective source match equivalent return loss of about 42 dB – again, quite typical at these frequencies.

The effective source match response in the time domain is the average over the measured frequency range and will generally be better than the worst case frequency domain result. In addition, the accuracy in the time domain will be limited by dispersion in waveguide setups. The measurement will also be affected by the time domain settings on the VNA. As shown by [Figures 12](#) and [13](#), the time domain display will often result in a 1–4 dB optimistic result for effective source match as compared to the worst-case frequency domain ripple measurement.

Frequency Response Tracking

The precision air line and flush short included in the Maury calibration kits can also be used to measure both transmission and reflection response residual tracking errors.



Residual reflection response tracking is measured by connecting the air line/short combination to the incident port and measuring S11 in the frequency domain with the time domain gate centered on the short at the end of the line. The air line or straight section is generally considered to have no loss.

Residual transmission response tracking is determined by measuring the S21 response of the precision air line connected between the two test ports. The air line is considered to have no loss in this case also.

Effective Load Match

The precision air line and time domain gating are also used to evaluate the residual load match error. The air line is connected between the test ports separating the directivity and load match S11 responses in time. The gate is then centered on the transmission port (Port 2 in Figure 1) to isolate the effective load match response.

Random and Other Non-Correctable Errors

This group of errors is an ultimate limit upon the performance of the VNA system because no compensation or correction mechanism exists. Among these are:

Connection Repeatability

Changes in the transmission and/or reflection characteristics of the interface between the test port and the DUT are a major source of error after calibration.

In coaxial setups, repeatability is a function of the condition of the connectors and the consistency of the applied mating torque. The latter, although important in all connector types, is especially critical in the smaller, higher frequency series such as 3.5mm. A calibrated torque wrench is an absolute must for 3.5 millimeter and smaller connector sizes³. The connectors should be cleaned before each use to remove metallic scrubbing residue from prior connections, dust, etc.

Serious consideration should be given to the use of test port adapters on coaxial test sets even if the DUT is directly mateable to the test port⁴. This is an inexpensive means of extending the life of the test port connectors, maintaining good repeatability, and, incidentally, avoiding large repair bills due to damage or wear of the test port connectors.

In waveguide systems, connection inconsistency is usually the result of flange misalignment. In general, standard UG type flanges require extremely careful connection to achieve even barely acceptable repeatability. This is particularly true in millimeter waveguide sizes even with flanges incorporating the 4-pin alignment pattern. Another problem with such flanges is the raised boss in the center. If the flange screws are pulled up unevenly, the flange can be cocked causing flange loss to vary from connection to connection.

The Maury solution to flange repeatability errors is illustrated in Figure 14. The Maury MPF series precision flanges² include two slip-fit indexing pins and indexing holes located on the center line of the broad dimension of the waveguide to prevent misalignment, while the addition of an outer ring prevents flange cocking as the flange screws are tightened.

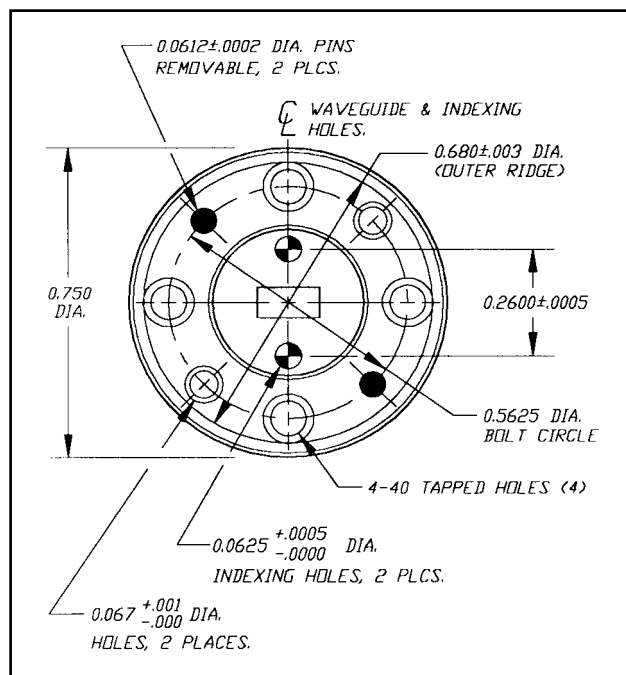

Figure 14. MPF15 and MPF12 Flanges will Mate with Appropriate UG Flanges. 0.0612 Pins are Removable for Mating with Other Precision MPF Flanges

The MPF flanges illustrated also include the standard 4-pin pattern for use when the flange must mate with a UG type flange. These pins and the precision indexing pins are removable, allowing the flange surface to be serviced in the event of damage. The MPF "A" flanges (not shown) do not include the 4-pin pattern and are used when mating to other Maury precision flanges.



The performance of the Maury precision flanges in comparison to the UG type flange is illustrated by **Figures 15** and **16**. **Figure 15** shows the repeatability of the standard UG385/U flange using

same as the effective directivity while the Maury flange shows a 20–30 dB improvement.

Cable Repeatability

In millimeter waveguide setups, the coupler outputs of the test set heads in **Figure 1** are each applied to harmonic mixers. While the signal connections to the mixers are usually rigid, the local oscillator signal, typically in the 3–6 GHz range, is applied via flexible cable to one of the test heads to facilitate insertion of the DUT or calibration and verification devices.

The cable phase stability is a function of mechanical stability, severity of deformation, and temperature. Good performance at millimeter wave frequencies is helped by keeping movement to a minimum, making all bend radii as large as possible, and keeping the number of bends to a minimum. With careful setup and operating technique, it is possible to hold the cable phase to within $\pm 1^\circ$ at the RF corresponding to about $\pm 0.1^\circ$ at the LO fundamental.

Trace Noise

Trace noise refers to the stability of the trace on the display. It limits the maximum resolution of the VNA. Trace noise is measured by measuring the S21 of a thru connection (test ports connected together) and expanding the display resolution so the noise is visible. Trace noise is primarily a random phenomenon; therefore, the amplitude of the noise is a function of the averaging factor. A higher averaging factor would reduce the noise; however, the trade-off would be a slower measurement.

At lower microwave frequencies, the trace noise typically decreases to a few thousandths of a dB; about 0.01 dB is typical at millimeter wave frequencies.

Noise Floor

The noise floor of the analyzer is the ultimate limit on the sensitivity of the instrument and, therefore, has an effect on the dynamic range. The noise floor is primarily determined by the noise figure of the mixers and is measured by terminating both test ports and measuring S21. About -90 dB relative to a thru connection is typical in WR15. The actual noise floor is a function of the averaging used.

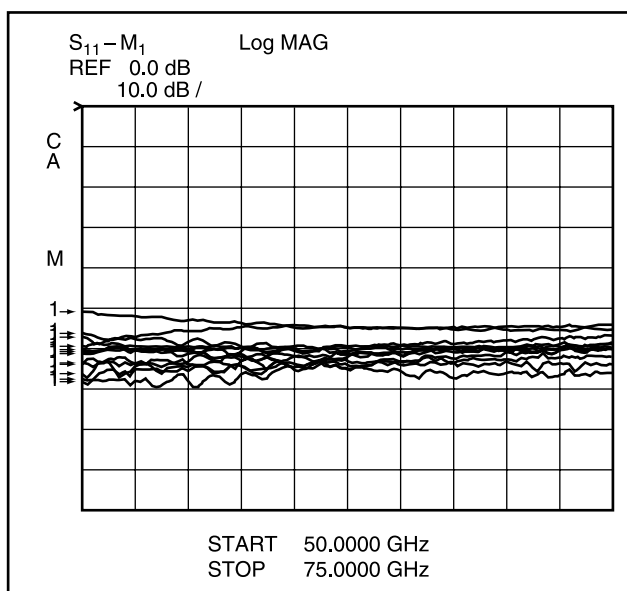

Figure 15. Repeatability of UG385/U Flanges

very careful connection procedures. **Figure 16** is the repeatability of the Maury flange with no special precautions taken during connection. These plots were generated by measuring the S11 of a fixed load and storing the data. The load was repeatedly disconnected, reconnected and measured, and the stored data was vectorally subtracted. Note that the repeatability of the UG flange is about the

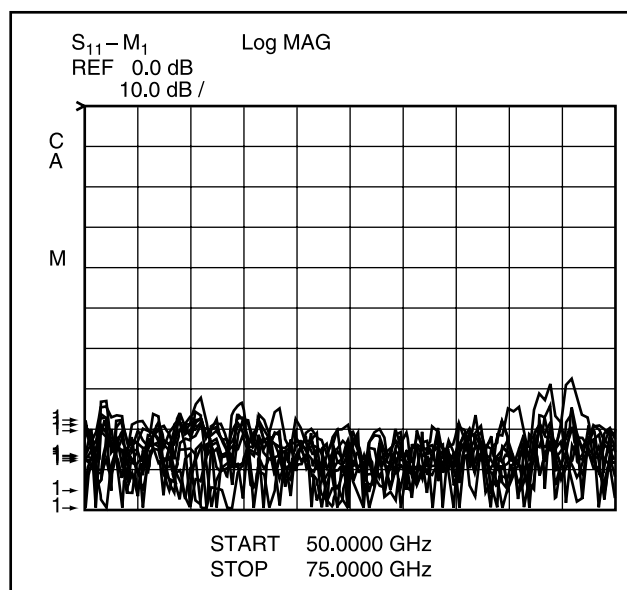

Figure 16. Repeatability of Maury MPF15 Precision Flanges



Increasing the averaging factor would reduce the noise; however, the measurement time would increase.

Spurious Signals and Dynamic Range

The local oscillators and signal sources used in network analyzers will almost always generate non-harmonic signals. The harmonic mixers used generate a multitude of in-band and out-of-band signals. If any of these spurious signals are separated from the LO frequency by the IF, they will be downconverted and appear as a signal at the IF output. The effect is a reduction in dynamic range evidenced by an apparent increase in the noise floor and becomes obvious when measuring transmission in the stop band of a filter – an area of high reflection.

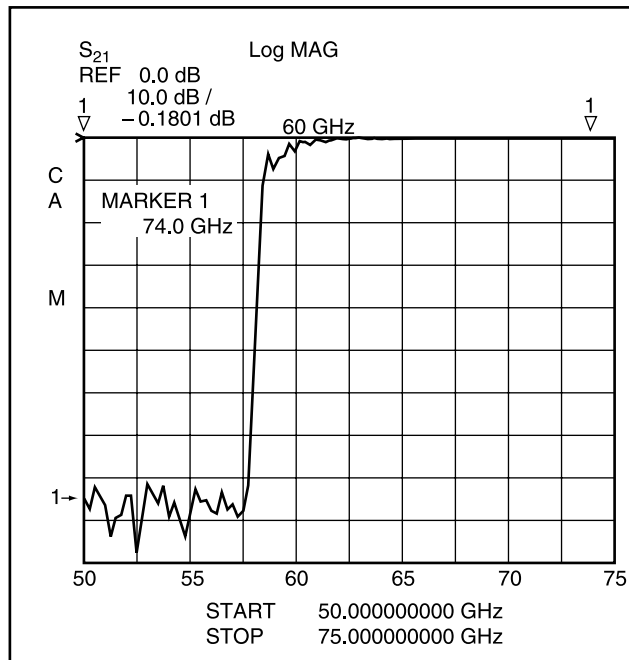

Figure 17. High Pass Filter Measurement

Figure 17 is an S21 plot of a very simply implemented high pass filter which can be used to check for spurious signals. The filter is the precision straight section from the Maury WR10 calibration kit connected between the test ports of a WR15 system.

Significant spurious effects would be indicated by a transmission response about 20–30 dB higher in the stop band. Since the noise floor in this band was previously measured at about -95 dB and the level in the stop band is about -85 dB, it can be

concluded that there is about 10 dB of spurious leakage in the system.

Spurious signal effects can be reduced by inserting isolators between each coupler output and mixer input ports.

Conclusions and Summary

VNA calibration, although currently very useful in removing the effects of systematic errors, always result in some residual errors. The magnitude of these residuals could have an impact on the DUT measurements depending on the magnitude of the DUT parameters, the type of measurement, and the extent of the calibration.

The Maury VNA calibration kits contain items which, while not used in the actual calibration, can be used to determine the effectiveness of the calibration for a specific measurement. These same items can also be used to determine whether the random errors are sufficiently small to be ignored.

References

- 1 A representative listing of VNA calibration kits can be found on pages 1-48 in the Maury catalog, 1G-003 2/2006 edition. You can also find this same information on our web site at: <http://www.maurymw.com/products/pcs/cxcalkits/coaxkits.htm>. Please contact our Sales Department for details on specific kits.
- 2 Maury Jr., M. A. and Simpson, G. R., "Improved Millimeter Waveguide Flanges Improve Components and Measurements", Microwave Journal, Vol. 29, No. 5, May 1986. Also Maury Data Sheets 5E-030 and 5E-031.
- 3 Data sheet 2Y-050A lists Maury torque wrenches applicable to coaxial connectors. (See also, our web site at <http://www.maurymw.com/products/pcs/trqwnchs/torqwrnchs.htm>.)
- 4 A representative listing of test port adapters can be found on pages 134-136 in the Maury catalog, 1G-003 2/2006 edition. You can also find this same information on our web site at: http://www.maurymw.com/products/rfacc/tprtadapts/tp_adaptrs_cx.htm and http://www.maurymw.com/products/rfacc/tprtadapts/tp_adptrs_wg.htm. Please contact our Sales Department for details on specific adapters.