

# TYPE N PRECISION CONNECTOR GAGE KIT

## A020A

### Key Features

- **Direct Reading**
- **Self-Checking**
- **Accurate**
- **Easy To Use**



**A020A Type N  
Precision Connector Gage Kit**

### Description

The model A020A connector gage kit is designed to measure the center contact pin location from the outer conductor mating surface of precision type N female and male connectors per MIL-C-39012, MIL-T-81490 and Maury precision. Refer to dimensions A and B in **Figure 1** and **Table 1**.

This gage kit provides a fast and accurate means for checking connectors for compliance to applicable interface specifications. Since it is basically a comparator, it can be used to check a variety of nominal dimensions. The indicator is zeroed by means of a master gage with the appropriate nominal dimension; then, it is engaged to the connector being tested. The resultant reading is the actual deviation from the nominal dimension. The accuracy of the measurement is the tolerance of the master gage nominal dimension itself.

The model A020A consists of a precision dial indicator assembly, interchangeable female and male measurement bushings and a master gage supplied in a wood instrument case with complete operating instructions. All gage parts

and the master gage are made from stainless steel for long wearing characteristics.

The model A020A is very useful in a variety of applications such as: production checkout, incoming inspection, quality control and in the laboratory.

### Specifications

Connectors Measured.....Precision N,  
female and male

Interface Specifications:

- MIL-C-39012 (Standard Test Connector)
- MIL-T-81490 and Maury Precision Type N (5E-049)

Dial Indicator .....2-1/4 dia. (0.00025 Graduations)

Master Gage Dimensions.....0.207 female and male

Accuracy of Measurement (\*) ..... Refer to **Table 3**

Case Dimensions (inches)..... 6.0 L x 4.0 W x 2.0 D

(\*) Applies to S/N 2586 and on.



## Options And Accessories

Master gages — refer to **Figure 2**. Maury produces master gages for checking all interface dimensions per **Table 1**. Please refer to **Table 2** for available master gages.

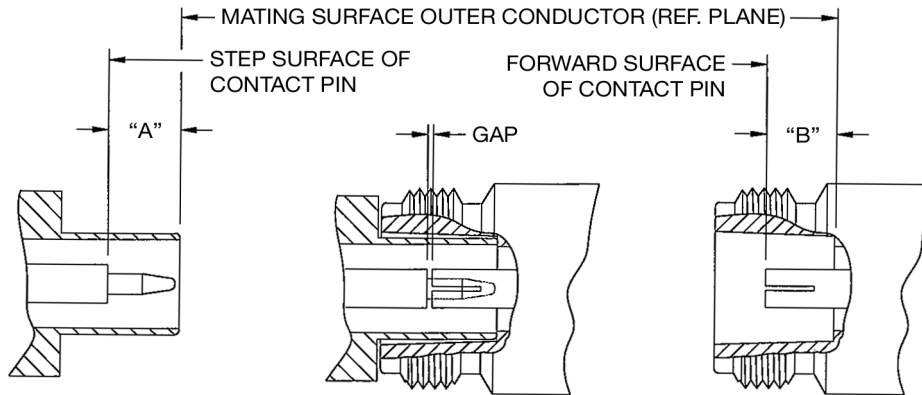

**Figure 1**

**Table 1. Contact Pin Locations for Commonly used Type N Connectors**

ITEM	SPECIFICATION	A		B		GAP (See <b>Figure 1</b> )			COMMENTS
						MIN	NOM	MAX	
A	Maury High Precision	0.2070	+0.0005 -0.0000	0.2070	+0.0000 -0.0005	0.0000	0.0000	0.0010	MMC High Precision type N Connector
B	Maury Precision (per Maury data sheet 5E-049)	0.207	+0.003 -0.000	0.207	+0.000 -0.003	0.000	0.000	0.006	MMC Precision Type N Connector <sup>1</sup>
C	—	0.207	+0.010 -0.000	0.207	+0.000 -0.010	0.000	0.000	0.020	<sup>2</sup>
D	MIL-C-39012 Class 1	0.208	+0.003 -0.000	0.207	+0.000 -0.003	0.001	0.001	0.007	MIL-C-39012C Standard Test Connector
*E	MIL-C-39012 Class 2	0.210	+0.020 -0.000	0.207	+0.000 -0.020	0.003	0.003	0.040	Type N General Specification <sup>3</sup>
F	MIL-T-81490	0.208	+0.003 -0.000	0.207	+0.000 -0.003	0.001	0.001	0.007	MIL-T-81490 Type EW Connectors

\* The Maury A007A kit is designed to measure this specification.

### Notes

- <sup>1</sup> Precision connector compatible with most precision type N connectors in use today.
- <sup>2</sup> Maury's general purpose type N connector per MIL-C-39012C except dimension A is reduced and the tolerances are tighter.
- <sup>3</sup> Maury recommends that for better quality the following tolerances be used: A = 0.210  $\begin{matrix} +0.010 \\ -0.000 \end{matrix}$  B = 0.207  $\begin{matrix} +0.000 \\ -0.010 \end{matrix}$
- <sup>4</sup> Type N male connectors may be slotted or not; MIL-C-39012 and MIL-T-81490 provide this option. Items A, B, C, and D are not slotted. Items E and F may or may not be slotted.

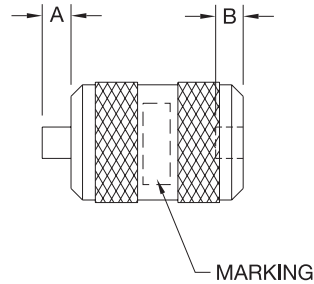

Figure 2

Table 2. Master Gages				
MODEL	A	B	MARKED	REFERENCE
A005S31	0.197 ±0.0005	0.223 ±0.0005	N	MIL-C-71B
A005S32	0.207 <sup>+0.000</sup> -0.001	0.210 <sup>+0.001</sup> -0.000	N — 2	MIL-C-39012 Class 2
A005S34	0.207 <sup>+0.0000</sup> -0.0005	0.208 <sup>+0.0005</sup> -0.0000	N — 3	<sup>5</sup>
A005S35	0.207 <sup>+0.0000</sup> -0.0005	0.207 <sup>+0.0005</sup> -0.0000	N — 4	<sup>6</sup>

### Notes

<sup>5</sup> MIL-C-39012 standard test connector and MIL-T-81490.

<sup>6</sup> Supplied in model A020A.

**Table 3. A020A Connector Gage Specifications**

CHARACTERISTICS	LIMITS	COMMENTS
Gage Resolution	$\pm 0.000050$	1/5 Least dial graduation <sup>7</sup>
Gage Calibration Accuracy <sup>11</sup>	$\pm 0.000375$	1 Least dial graduation <sup>8</sup> plus 0.000125 measurement guardband
Gage Repeatability	$\pm 0.000050$	1/5 Least dial graduation <sup>8</sup>
Master Accuracy	$\pm 0.000250$	0.00050 Range <sup>9</sup>
Total Uncertainty <sup>10, 11</sup>		
RSS	$\pm 0.000456$	Root sum of the squares.
Worst Case	$\pm 0.000725$	Add resolution, repeatability, gage and master accuracy limits.

## Notes

<sup>7</sup> Per ASME B89.1.10M-2001, C5.1.2.

<sup>8</sup> Per ASME B89.1.10M-2001, Table 2.

<sup>9</sup> Per manufacturer's specification.

<sup>10</sup> Performance standards are in compliance with ANSI/NC SL Z540-1, MIL-STD-45662A and ISO 10012-1.

<sup>11</sup> Applies over the operating range for connector gaging +0.011/-0.001" from master gage zero setting.