

# INTERFACE DIMENSIONS

## LPC7A COAXIAL CONNECTOR

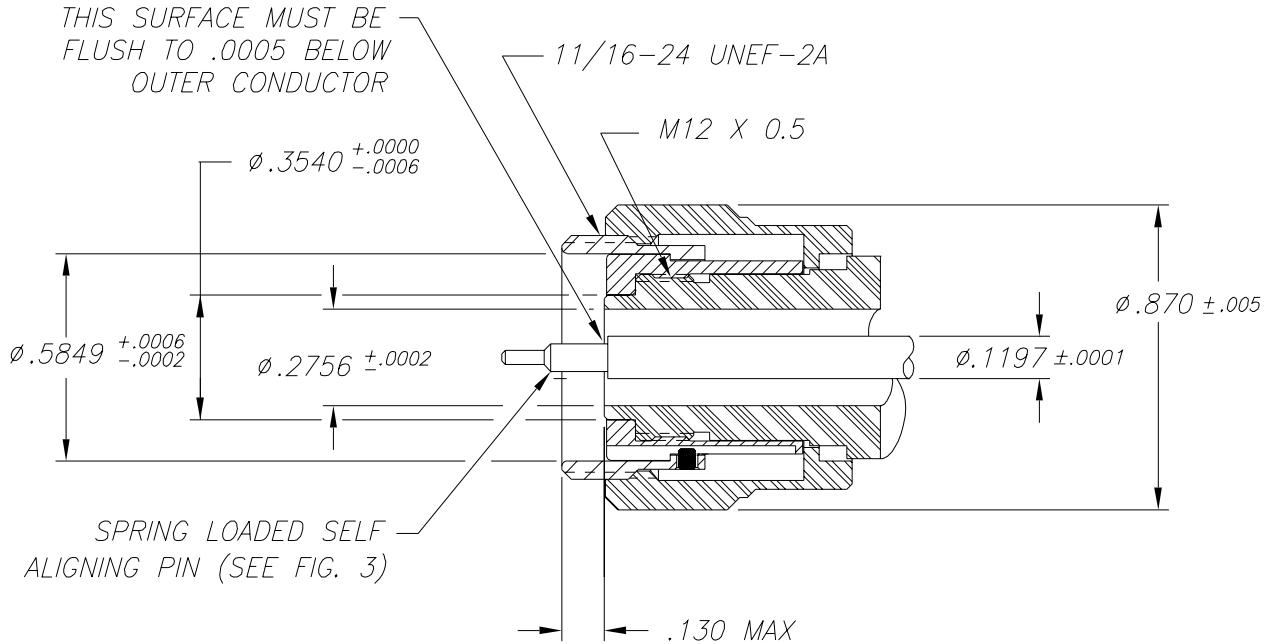

Figure 1: Sleeve Extended (LPC7)

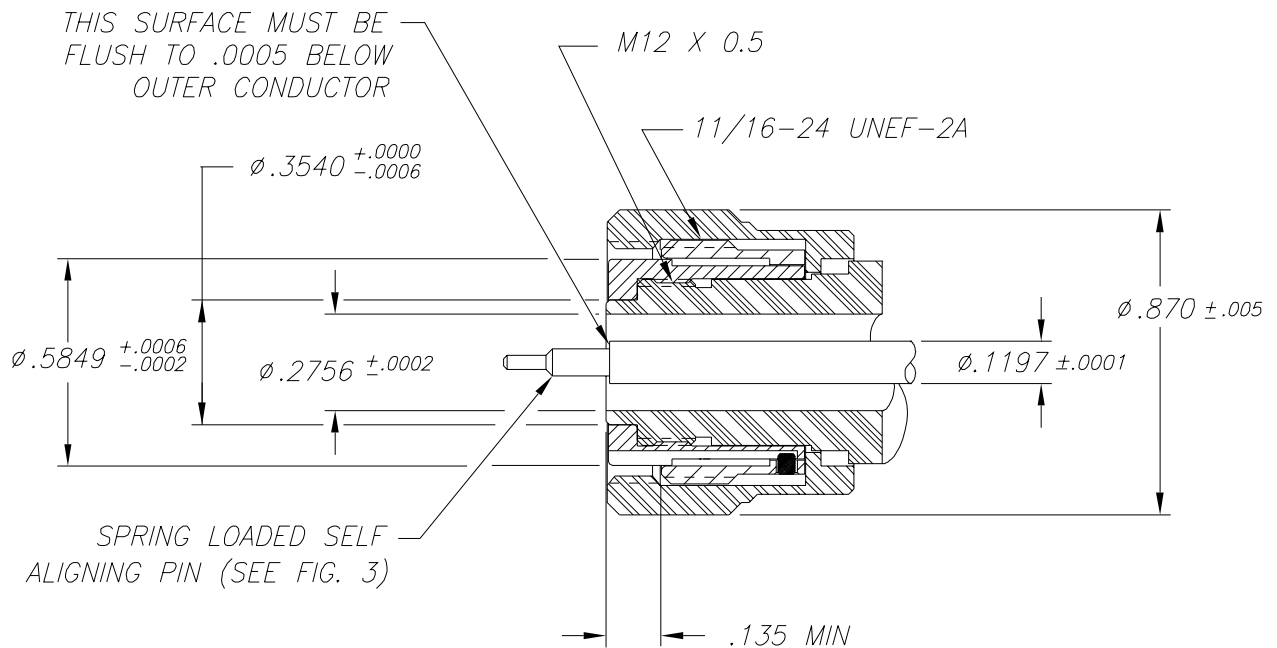
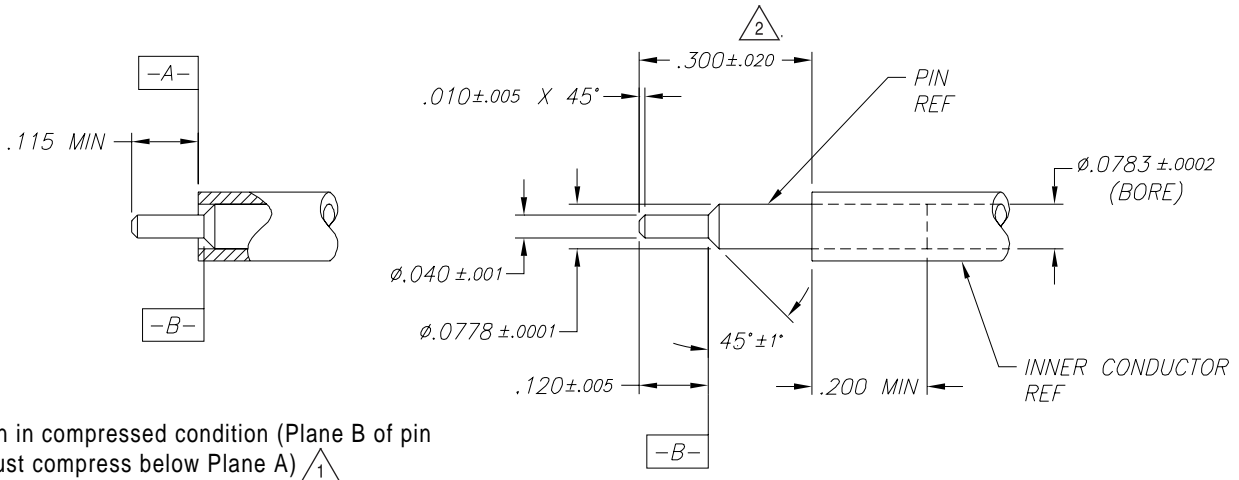

Figure 2: Sleeve Retracted (LPC7)



△<sub>1</sub> Based on 0.8 lbs. maximum      △<sub>2</sub> Dimension on 2653C to H air lines is  $0.225 \pm 0.020$

Figure 3: Spring Loaded Self-Aligning Pin

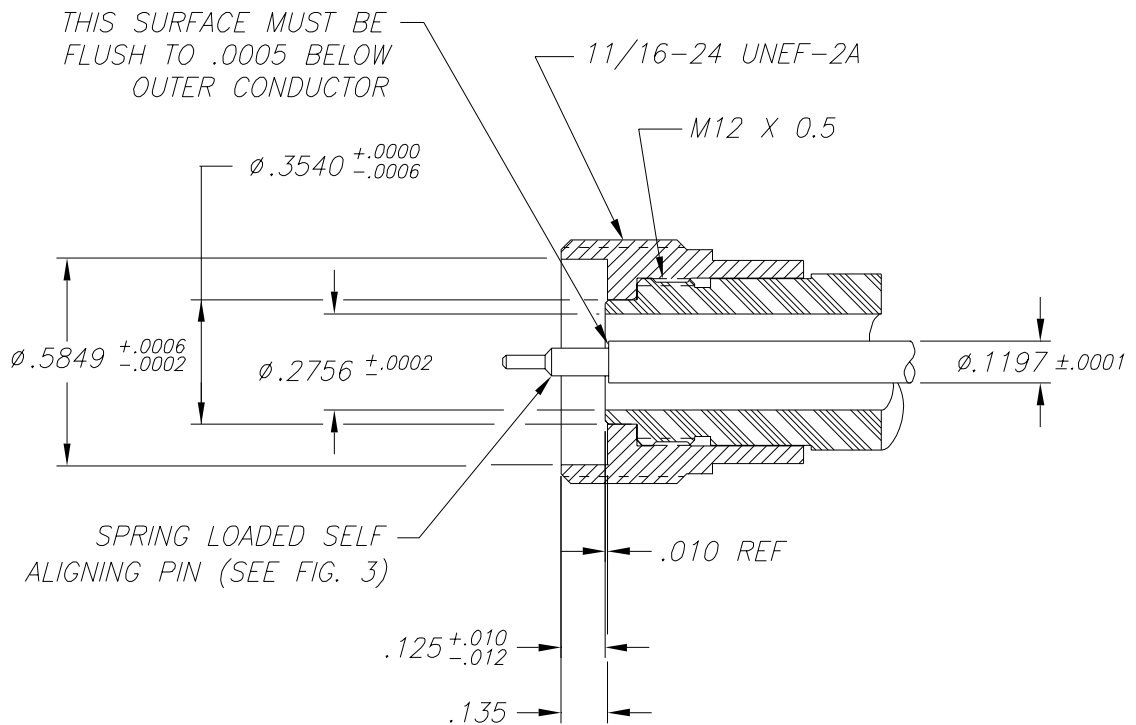

Figure 4: Rigid Coupling (LPC7F) – Provided on 2653S( ) Series Air Lines