

# "METROLOGY GRADE" 1.85/2.4mm DIGITAL CONNECTOR GAGE KIT

## Features

- $\pm 0.0018\text{mm} \pm 0.00007$  inches Gage Repeatability • Multiple Applications
- "Thread-On" for Higher Accuracy



A048A

## Description

The Maury model A048A connector gage kit is designed to measure 1.85/2.4mm connectors with either female or male interfaces. The digital indicators used in the A048A connector gage kit provide a measurement resolution of .001mm (0.000040 inches) when used in the metric mode. Maury recommends that all 1.85/2.4mm connectors are gaged with the indicators in the metric mode to take advantage of the higher resolution provided in that mode. Excellent repeatability is achieved by maintaining tightly controlled tolerances on all machined parts. See [Figure 1](#).

The Maury connector gage assemblies use a "thread-on" design that simulates actual mating conditions. Critical contact pin locations can be read directly on the digital indicator. Centering sleeves are provided for measuring beadless air lines and 2-port standards. Flush setting sliding loads is easily accomplished using the A048A gages.

Maury models A048A1 (female) and A048A2 (male) connector gages are compatible with Mitutoyo SPC Digimatic output for external display of data. Use data cable A04853 or A04854. All machined parts are made from heat treated stainless steel to assure long life and superior stability. Gaging surfaces are lapped to ensure a high degree of accuracy.

**NOTE:** The A048A is a metrology grade connector gage and should be used for gaging 1.85/2.4mm connectors *only*.

Digital Gage  
A048A2



Master Gage  
A048A4



Digital Gage  
A048A1



Master Gage  
A048A3



## Applications

The critical contact pin locations of 1.85/2.4mm female and male precision connectors are shown in [Figures 2](#) and [3](#). These dimensions must be maintained in order to provide proper electrical performance and mechanical mating of female and male connectors. These connectors are designed to achieve a co-planar mating at the outer conductor mating plane, i.e., a metal contact at the outer conductor mating plane. Destructive interference may result if the contacts protrude beyond the outer conductor mating planes which may cause buckling of the female contact fingers, or damage to associated equipment during mating. Also, an excessive gap of the center contacts when mated produces high reflections and causes breakdown under peak power conditions.

All connectors should be gaged after assembly or prior to use to insure compliance to applicable specifications to prevent destructive interference, and to insure electrical performance. In addition, connectors on all equipment should be gaged periodically to detect out of tolerance conditions which may impair electrical performance, or cause damage to mating connectors.

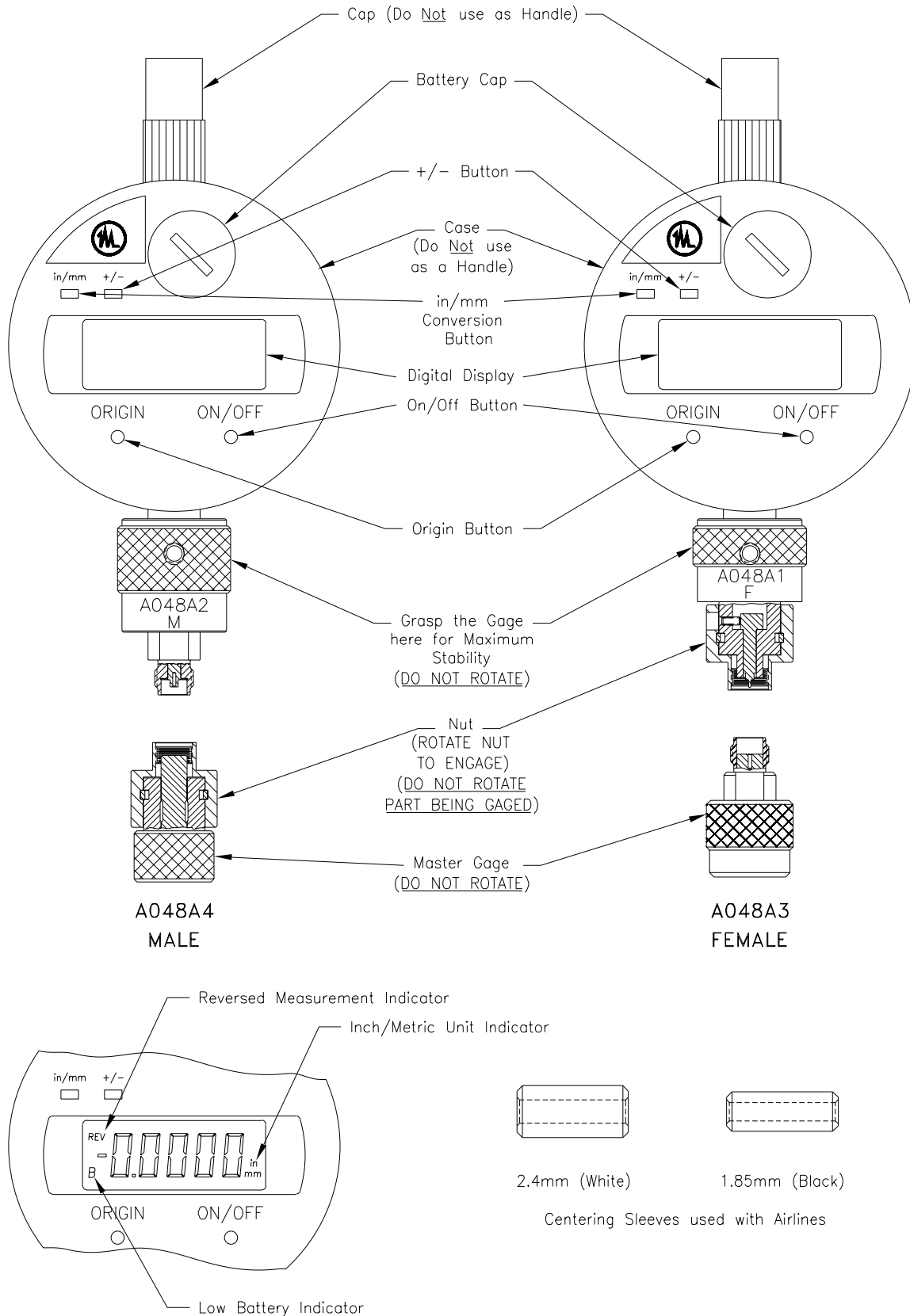
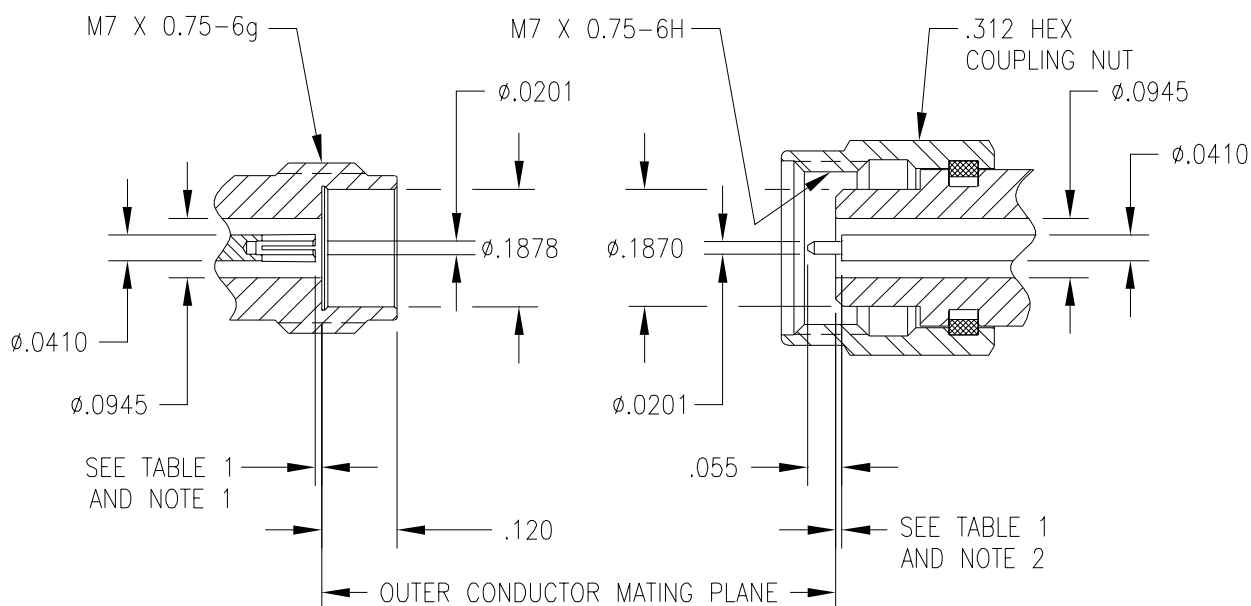

Figure 1. The A048A Connector Gage Kit



| 2.4mm<br>Connector Gage         | Pin Depth Specifications |                  |              |                    |
|---------------------------------|--------------------------|------------------|--------------|--------------------|
|                                 | mm                       |                  | inches (Ref) |                    |
| IEEE-287 GPC                    | 0.000                    | +0.050<br>-0.000 | 0.0000       | +0.0020<br>-0.0000 |
| IEEE-287 LPC                    | 0.000                    | +0.013<br>-0.000 | 0.0000       | +0.0005<br>-0.0000 |
| Maury Precision<br>(SEE NOTE 3) | 0.000                    | +0.038<br>-0.000 | 0.0000       | +0.0015<br>-0.0000 |

Table 1. 2.4mm Connector Grade Specifications

## Notes

- 1 Female contact pin location — use gage assembly marked “F”.
- 2 Male contact pin location — use gage assembly marked “M”.
- 3 Tighter tolerances can be used at user’s discretion. For high precision calibration components, Maury recommends and uses +0.000 to +0.013mm (+0.0000 to +0.0005 inches) for center contact pin shoulder recession behind the outer conductor mating plane.
- 4 In reference to the outline drawing above: Minus (-) tolerances indicate a protruding condition above the outer conductor mating plane. Plus (+) tolerances indicate a recessed condition below the outer conductor mating plane.
- 5 Other dimensions shown in this figure are shown since they affect the mating of the gage assemblies’ gaging mechanisms (bushing and pin). Deviation from these dimensions may cause measurement errors or improper fit between the gaging mechanisms and the connectors being measured. Consult our Customer Service Department on measuring connectors with interface dimensions other than specified above.

Figure 2. Critical Contact Pin Location Dimensions of 2.4mm Precision Connectors

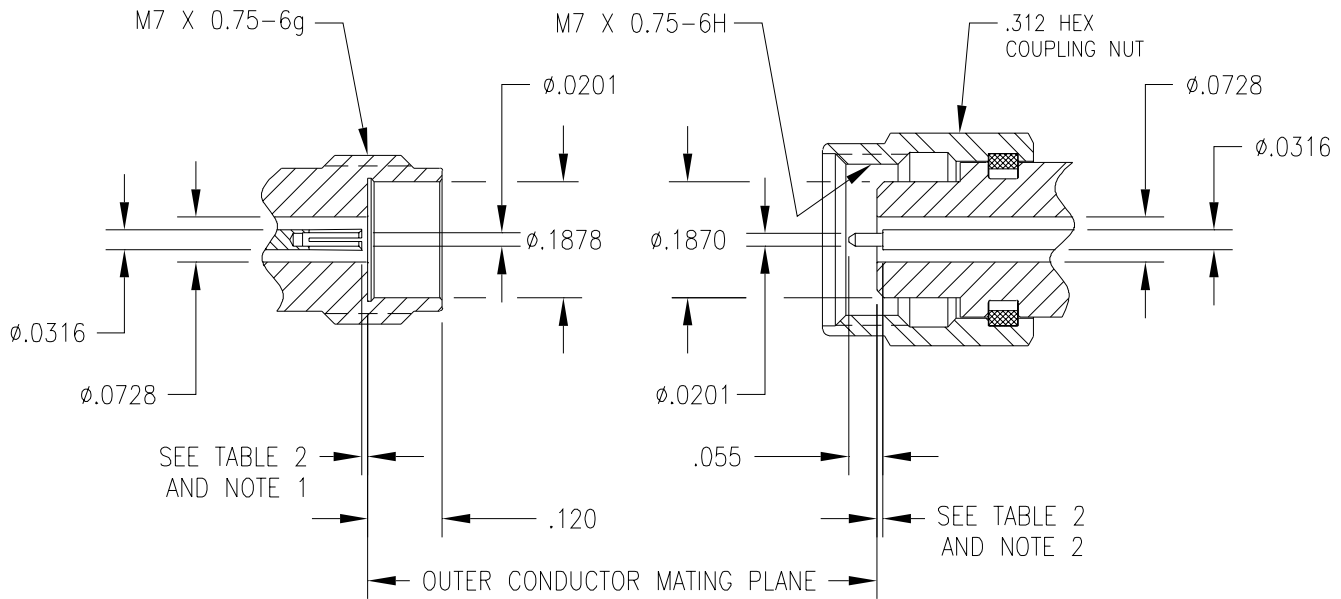

| 1.85mm<br>Connector Gage        | Pin Depth Specifications |                  |              |                    |
|---------------------------------|--------------------------|------------------|--------------|--------------------|
|                                 | mm                       |                  | inches (Ref) |                    |
| IEEE-287 GPC                    | 0.000                    | +0.050<br>-0.000 | 0.0000       | +0.0020<br>-0.0000 |
| IEEE-287 LPC                    | 0.000                    | +0.013<br>-0.000 | 0.0000       | +0.0005<br>-0.0000 |
| Maury Precision<br>(SEE NOTE 3) | 0.008                    | +0.015<br>-0.000 | 0.0003       | +0.0006<br>-0.0002 |

Table 2. 1.85mm Connector Grade Specifications

Notes

- Female contact pin location — use gage assembly marked “F”.
- Male contact pin location — use gage assembly marked “M”.
- Tighter tolerances can be used at user’s discretion. For high precision calibration components, Maury recommends and uses +0.000 to +0.013mm (+0.0000 to +0.0005 inches) for center contact pin shoulder recession behind the outer conductor mating plane.
- In reference to the outline drawing above: Minus (-) tolerances indicate a protruding condition above the outer conductor mating plane. Plus (+) tolerances indicate a recessed condition below the outer conductor mating plane.
- Other dimensions shown in this figure are shown since they affect the mating of the gage assemblies’ gaging mechanisms (bushing and pin). Deviation from these dimensions may cause measurement errors or improper fit between the gaging mechanisms and the connectors being measured. Consult our Customer Service Department on measuring connectors with interface dimensions other than specified above.

Figure 3. Critical Contact Pin Location Dimensions of 1.85mm Precision Connectors