

2.4mm AUTOMATED TUNERS

8 To 50 GHz

Features

- Optimized for X-Band, Ku-Band, K-Band, Ka-Band, Microwave and mm-Wave Noise and Power Applications
- High matching Range for GaN, InP, InGaP, GaAs, LDMOS, Si, and CMOS Device Characterization
- Simultaneous High Matching and Ultra-Low Vibration for On-Wafer Applications
- USB Interface for Simple, Fast, and Reliable Control
- Optimized for mm-Wave Power and Noise Applications
- Ideal for Broad-Band Noise Parameter Extraction and Noise and large-Signal Nonlinear Model Verification
- DLL Environment for Automated Applications



MT984AU01
2.4mm 50 GHz Automated Tuner

Applications and Benefits Overview

The MT984AU01 automated tuners are optimized for a broad class of microwave and millimeter-wave applications requiring flexibility, broad frequency coverage and ease of use. Based on Maury's proven non-contacting probe technology, these high-performance tuners evolve beyond outdated contacting probe technology to deliver high VSWR with superb accuracy and reliability. An integral component of Maury's Device Characterization Solutions, these PC-based USB-interface automated tuners are controlled using Maury's family of Device Characterization Software tools including the ATS Version 5 (or later) interactive environment and the DLL-based measurement automation environment. The ATS interactive environment is an integrated device characterization environment providing comprehensive calibration and device characterization tools for power and noise optimization. The DLL environment enables direct interface with common programming tools such

Agilent VEE™, NI Labview™, MS Visual Basic & C/C++, and Mathworks MATLAB™. With a tuning resolution in excess of a million impedance points and accuracy better than -40 dB over the entire Smith Chart, Maury automated tuners give you the device characterization answers you need with the accuracy necessary to make engineering decisions with confidence. Typical applications include load-pull for CW and pulsed or modulated X-band, Ku-band, Ka-band design and Sat-Com design, and source pull for CMOS and GaAs low noise characterization to 50 GHz. Available in 2.4mm connector.

Controller

For optimum performance, the MT1020B ATS Power Distribution Hub can be used to control up to four (4) MT984 series tuners. Additionally, the MT1020D Desktop Switching Power Supply can be used to provide power to a single MT984 series tuner.

Trademarks shown above are the property of their respective owners.



Specifications

Frequency Range See **Available Models Table**
 VSWR Matching Range... See **Available Models Table**
 Step Size (Probes)..... 31 microinches¹
 Step Size (Carriage) 50 microinches¹
 Connectors Precision 2.4mm (female and male)²

Recommended Accessories

8799A1 2.4mm (5/16-in. hex) torque wrench
 A048A 2.4mm/1.85mm digital connector gage kit
 MT900 Probe station integration

Accessories Provided

One MT1020D controller, one USB cable and one operating manual.

Available Models

Model	Frequency Range (GHz)	Matching Range		Power Capability ⁴	Vector Repeatability (Minimum)	ΔG_t (Typical)	VSWR ⁵ (Maximum)	Insertion Loss ⁵ (Maximum)	Dimensions
		Minimum	Typical ³						
MT984AU01	8.0 — 50.0	10:1	20:1	10 W CW 100 W PEP	-40 dB	± 0.2 dB	1.15:1	0.65 dB	7.1" x 9.8" x 5.2" (19.0cm x 24.9cm x 13.2cm)

Dimensions (Inches)

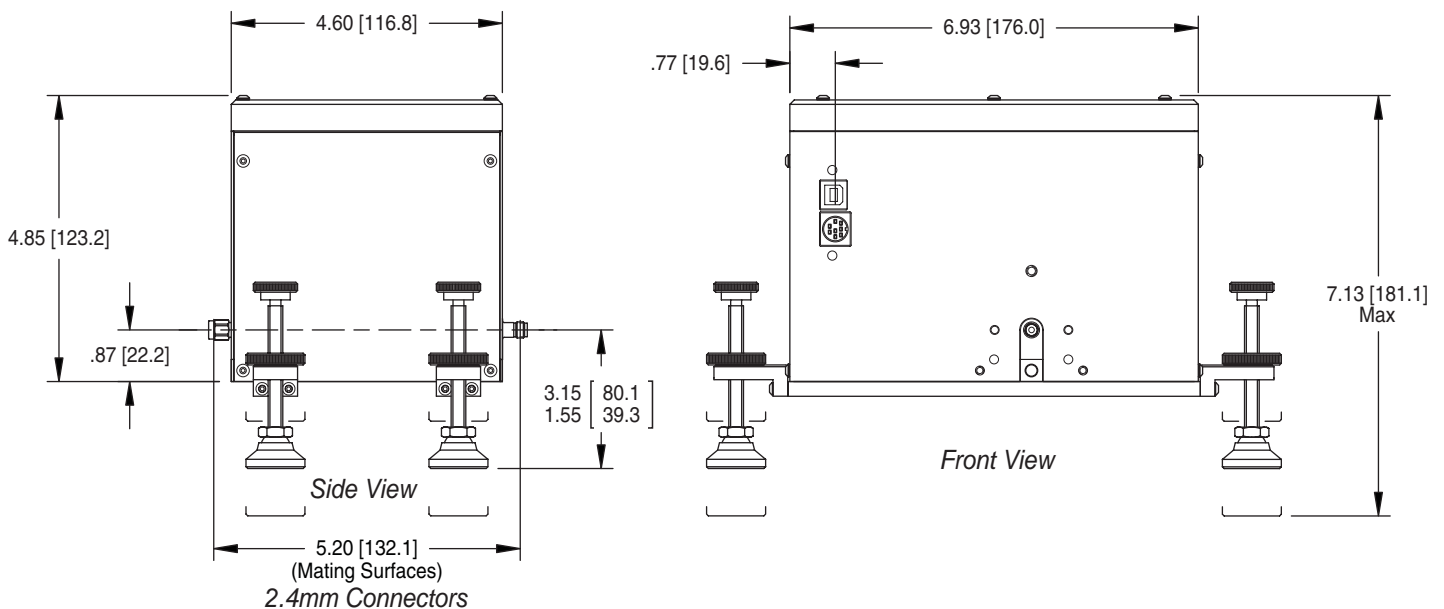

¹ Based on 1/2 stepping the drive motors.
² Precision 2.4mm per Maury data sheet 5E-064.
³ Defined as the maximum VSWR within 20% of the peak VSWR.

⁴ Power rated at maximum VSWR.
⁵ With probes fully retracted.