



NOISE CALIBRATION SYSTEM

COAXIAL - DUAL LOADS

Features

- Accurate
- Convenient
- Broadband
- Multiple Applications

Description

The Maury MT7098B is an automatic, self-contained system that provides two accurately known, switched thermal noise powers at a single precision coaxial output port. It is designed for highly accurate noise figure or effective input noise temperature measurements, calibration of less accurate solid state noise generators, and performance evaluation and verification of satellite earth station receivers. Application note 5C-028 provides more details on these measurement procedures.

In many critical, low noise measurement applications, solid state noise generators are not sufficiently accurate. The typical, general purpose laboratory unit will exhibit hot temperature uncertainties in the order of ± 200 to ± 700 kelvins (K). The worst case temperature uncertainty of the MT7098B is better than ± 2 K. In a measurement of an amplifier with an effective input noise temperature of 100K, this can result in an improvement of measurement uncertainty due to temperature errors of **about 30%!**

The accuracy of the MT7098B derives from the use of true thermal noise sources – the fundamental principle of noise generation – and highly accurate insertion loss measurements of the interconnecting transmission structure (primarily the hot-cold selector relays).

The cold noise temperature is provided by a liquid nitrogen (LN₂) cooled termination (MT7118 series). An automatic level sensing/fill system maintains the proper operating level of liquid nitrogen (customer provided). The termination is pressurized to 2 pounds per square inch (PSI) using helium gas. Pressurization purges the termination of air, moisture vapor, carbon dioxide and

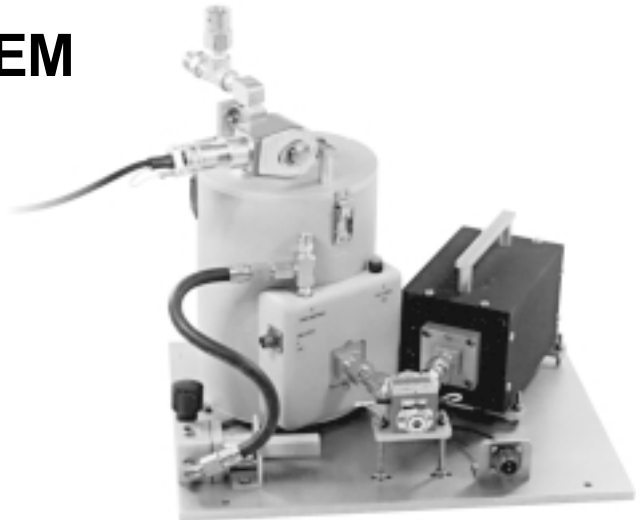

other contaminants which, if allowed to freeze, would alter the microwave characteristics of the termination structure. Pressure is maintained by a regulator which requires 20 PSI maximum from a customer provided external helium supply.

The hot noise source is a heated termination (MT7108 series) whose temperature, approximately that of boiling water (373.1K), is maintained by proportional control to better than ± 0.2 K by the MT155A controller. Actual temperature is indicated by a digital readout on the controller front panel.

The controller also contains automatic liquid nitrogen fill/sensing controls and the remote switch that controls the relays used to switch from one noise termination to another.

The MT7098B is comprised of three assemblies:

- A component mounting plate which holds the cryogenic termination, the thermal termination, the hot/cold remotely controlled relays and output assembly, and the helium pressure regulator. The LN₂ level sensor and fill solenoid are mounted on the cover of the LN₂ container.
- The MT155A controller which contains the proportional temperature control circuitry for the thermal termination, a digital temperature readout (heated termination only), the liquid nitrogen automatic or manual fill control circuitry, and the remote hot/cold switch. The controller is described in detail in data sheet 4F-003.
- The MT155B cable (25 feet) which connects the controller to the component mounting plate.



Calibration of the hot and cold noise temperatures [at the output connector](#) is provided at four frequencies as shown in the specifications. More calibration frequencies can be provided at additional cost (consult the factory for calibration charges). Note that the noise temperatures themselves are not critical; however, the accuracy to which they are known is important. Calibration accuracies are shown in Table II.

Each MT7098B noise calibration system is provided with a calibration report, operating instructions, and three technical notes which describe the calibration procedure and error analysis.

Maury also manufactures tri-load systems (hot, ambient, and cold) as well as individual cooled, ambient, and hot loads in both coaxial and waveguide.

Specifications

Frequency Range	DC to 18 GHz
VSWR (maximum):	
DC to 10 GHz	$1.10 + 0.01f(\text{GHz})$
10 to 18 GHz	1.20
Physical Termination Temperature:	
Cold Termination	77.36K
Hot Termination	373.1K
Hot Temperature Stability	$\pm 0.2\text{K}$ ($\pm 0.1\text{K}$ typical)
Available Output	
Noise Temperatures	See Table I for typical values
Calibration Accuracy	See Table II
Calibration Frequencies	As per Table II [1]
Output Connector	APC7S [2]
Pressurization	Helium at 20 PSI maximum
LN ₂ Dewar Capacity	1 liter
LN ₂ Operating Life	3 hours [3]
Operating Orientation	Horizontal
Mounting Plate Dimensions	See Figure 1
Power Requirements [4] :	
Option 03	120 VAC, 50/60 Hz
Option 04	100/120/220/240 VAC, 50/60 Hz

[\[1\]](#) Other frequencies available at additional cost.

[\[2\]](#) 7mm male connector mating compatible with standard 7mm precision unsexed connectors.

Table I
Typical Noise Temperatures
at the MT7098B Output Connector

Frequency Range (GHz)	Hot Temperature (K)	Cold Temperature (K)
3.95	371	83
7.50	369	88
12.40	366	95
18.00	365	98

Table II
Noise Temperature Calibration Accuracy

Frequency Range (GHz)	Temperature Uncertainty (\pm K)
3.95	1.0
7.50	1.2
12.40	1.5
18.00	2.0

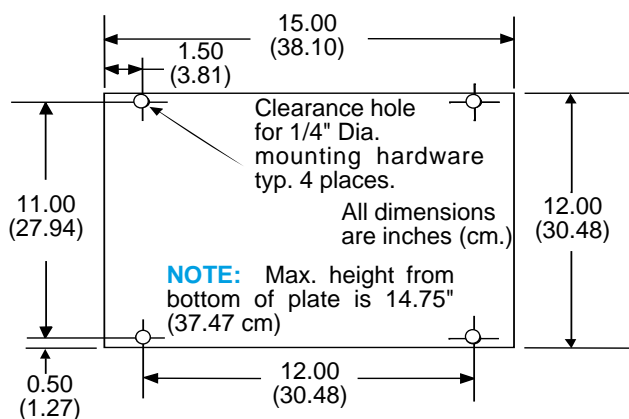

Figure 1
Component Mounting Plate Dimensions [\[5\]](#)

[\[3\]](#) Single fill only. Operation is continuous with automatic fill as long as the LN₂ supply lasts.

[\[4\]](#) Appropriate option must be specified at time of order.

[\[5\]](#) Outline and layout available on request.