

PRECISION CONNECTOR GAGE KIT

Features

- Direct Reading
- Self Checking
- Accurate
- Easy To Use

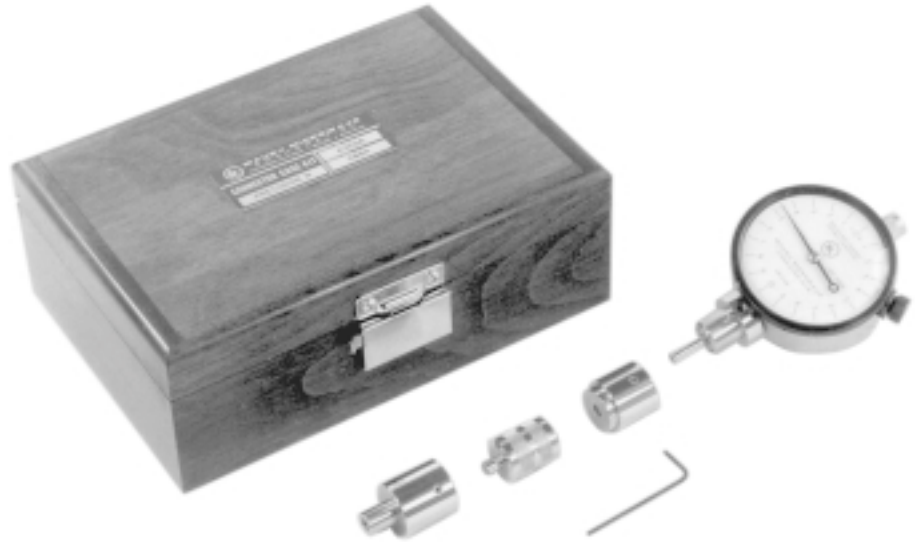

Description

The model A020A connector gage kit is designed to measure the center contact pin location from the outer conductor mating surface of precision type N female and male connectors per MIL-C-39012, MIL-T-81490 and Maury red dot. Refer to dimensions A and B in [Figure 1](#) and [Table 1](#).

This gage kit provides a fast and accurate means for checking connectors for compliance to applicable interface specifications. Since it is basically a comparator, it can be used to check a variety of nominal dimensions. The indicator is zeroed by means of a master gage with the appropriate nominal dimension; then, it is engaged to the connector being tested. The resultant reading is the actual deviation from the nominal dimension. The accuracy of the measurement is the tolerance of the master gage nominal dimension itself.

The model A020A consists of a precision dial indicator assembly, interchangeable female and male measurement bushings and a master gage supplied in a wood instrument case with complete operating instructions. All gage parts and the master gage are

made from stainless steel for long wearing characteristics.

The model A020A is very useful in a variety of applications such as: production checkout, incoming inspection, quality control and in the laboratory.

Specifications

Connectors measured	Precision N, female and male
Interface specifications	MIL-C-39012 (standard test connector), MIL-T-81490 and Maury red dot
Dial indicator	2-1/4 diameter 0.00025 graduations
Master gage dimensions	0.207 female and male
Accuracy of measurement (*)	female +0.0000 -0.0005 male +0.0005 -0.0000
Case dimensions (inches)	5.0 L x 3.0 W x 3.5 D

(*) Apply to S/N 2586 and on



Options And Accessories

Master gages — refer to figure 2. Maury produces master gages for checking all interface dimensions

per table 1. Please refer to table 2 for available master gages.

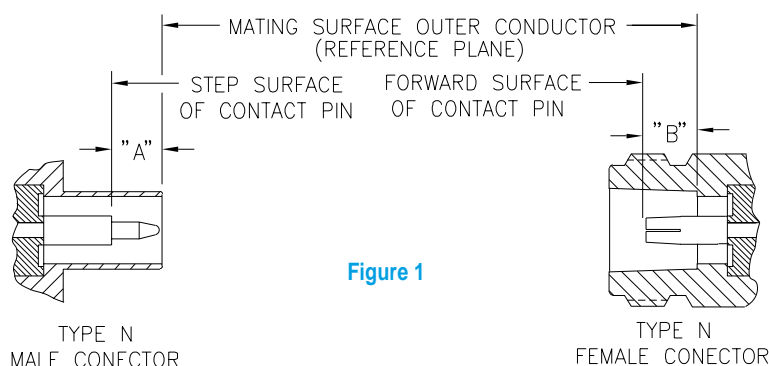

Figure 1

Table 1

Item	Military Specification	A	B	Center Contact Gap			Comments
				Minimum	Nominal	Maximum	
A	Red dot 5E-049	0.207 $\begin{smallmatrix} +0.003 \\ -0.000 \end{smallmatrix}$	0.207 $\begin{smallmatrix} +0.000 \\ -0.003 \end{smallmatrix}$	0.000	0.000	0.006	Maury precision type N connector ¹
B	—	0.207 $\begin{smallmatrix} +0.010 \\ -0.000 \end{smallmatrix}$	0.207 $\begin{smallmatrix} +0.000 \\ -0.010 \end{smallmatrix}$	0.000	0.000	0.020	²
C	MIL-C-39012 Class 2	0.210 min.	0.207 max.	³	0.003	³	Present type N specification ³
D	—	0.210 $\begin{smallmatrix} +0.010 \\ -0.000 \end{smallmatrix}$	0.207 $\begin{smallmatrix} +0.000 \\ -0.010 \end{smallmatrix}$	0.003	0.003	0.023	³
E	MIL-C-39012 Standard test	0.208 $\begin{smallmatrix} +0.003 \\ -0.000 \end{smallmatrix}$	0.207 $\begin{smallmatrix} +0.000 \\ -0.003 \end{smallmatrix}$	0.001	0.001	0.007	MIL-C-39012B per amendment 1
F	MIL-T-81490	0.208 $\begin{smallmatrix} +0.003 \\ -0.000 \end{smallmatrix}$	0.207 $\begin{smallmatrix} +0.000 \\ -0.003 \end{smallmatrix}$	0.001	0.001	0.007	MIL-T-81490 type 3 EW connectors
G	MIL-C-71B	0.223 ± 0.010	0.197 ± 0.010	0.006	0.026	0.046	Old type N specification ⁵
H	—	0.223 ± 0.005	0.197 ± 0.005	0.016	0.026	0.036	Maury precision type N equivalent to MIL-C-71B ⁵

¹ Precision connector compatible with most precision type N connectors in use today such as Amphenol APC-N and Weinschel 18 GHz connectors.

² Maury general purpose type N connector per MIL-C-39012 except dimension A.

³ Present dimensions in MIL-C-39012/1 and/2 and specify only one limit; i.e. there is no specified minimum limit for female connectors and no specified maximum limit for male connectors. Due to this, the center contact gap cannot be derived. In view of this, we recommend that tolerances as shown for item D be utilized when measuring connectors per MIL-C-39012.

⁴ Type N male connectors may be slotted or not; MIL-C-39012 and MIL-T-81490 provides this option. Items G and H are slotted. Items A, B, and E are not slotted. Items C, D, and F may or may not be slotted.

⁵ Use connector gage A007B. Do not use A020A.

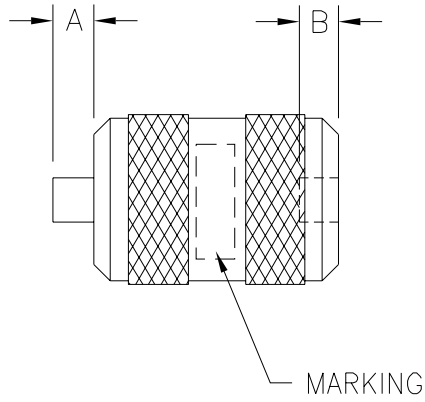

Figure 2

Table 2 — Master Gages

Model	A	B	Marked	Reference
A005S31	0.197 ±0.0005	0.223 ±0.0005	N	MIL-C-71B
A005S32	0.207 +0.000 -0.001	0.210 +0.001 -0.000	N — 2	MIL-C-39012 Class 2
A005S34	0.207 +0.0000 -0.0005	0.208 +0.0005 -0.0000	N — 3	[7]
A005S35	0.207 +0.0000 -0.0005	0.207 +0.0005 -0.0000	N — 4	[6]

[6] Supplied in model A020A.

[7] MIL-C-39012 standard test connector and MIL-T-81490.